

C15C

C15

Hyundai Theta Engine
or Yanmar Engine

15/18/20sC

IC-CUSHION LPG
3000 / 3500 / 4000 lbs.
(1500 / 1800 / 2000 kg)

15/18/20s

IC-PNEUMATIC LPG/DIESEL
3000 / 3500 / 4000 lbs.
(1500 / 1800 / 2000 kg)

GEN 2



CLARK®

THE FORKLIFT



98%

The two-stage engine air filter removes **Ninety-Eight Percent** of incoming dust before it enters the filter media.

- Nested upright rails provide positive rail interlock and a narrow "column" to **maximize the vision window**. The overhead guard safety bars run parallel to the operator's line of sight resulting in a **clear, unobstructed view**.

Maximum Visibility + Minimum Fatigue =
Ultimate Safety & Product Integrity

- The **operator compartment** is supported on specially engineered isolating mounts, reducing the amount of engine noise and vibration transmitted to the operator ensuring a more comfortable ride.

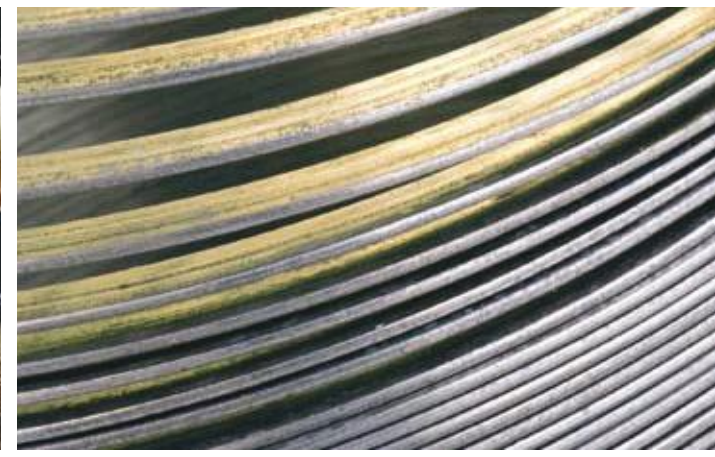

Highly Maneuverable, Easily Serviceable, Broadly Flexible, Extremely Dependable

The GEN2 C15-Series proudly adds to CLARK's unique history of building the best forklifts with evolutionary steps in **ergonomics, power, safety, durability** and **performance**. These narrow-width models, designed for distribution, manufacturing and warehousing of all types, are suited for the toughest applications.

• With four turns lock-to-lock the **hydrostatic power steering** provides the operator with excellent maneuverability and ease of control.



• Low, open foot steps with **traction plates** make entry/exit quick, easy, and safe.

10%

The high performance Hyundai Theta Engine is 10% more fuel efficient than prior EPA compliant models.

• Improved power and efficiency is achieved through comprehensive engine design integrating **multi-point sequential injection, dual overhead cams, four valves per cylinder, 10.5:1 high-compression** and **low friction diamond-like coating on cams & lifters.**

Smooth Control + Easy Operation = Operator Confidence & Optimum Comfort



Rugged Durability, High Performance, Extreme Environments, Demanding Applications

The GEN2 series is designed to tackle any task placed in its path. The open-core, plate-fin radiator provides **maximum cooling of the engine, transmission and axle in the harshest environments** and the most demanding applications.

C15 STANDARD FEATURES & BENEFITS



PARKING BRAKE

■ Simple & Error Proof

- Foot-applied brake can be released by hand or foot.
- Transmission disengages when parking brake is set preventing driving against brakes.
- Horn will sound if brake is not set after 3 seconds from when the engine is shut off.

HYDRAULIC SYSTEM

■ Maximum Horsepower

- Uses a load-sensing flow control valve for steering to reduce horsepower loss and heat buildup.

■ Optimum Performance Of Attachments

- The main hydraulic valve incorporates adjustable flow controls for tilt and auxiliary functions.

■ Sectional Design

- Allows for easy addition of extra functions and simplifies service.

■ Upright Mounted Load Lowering Valve

- Controlled lowering speed independent of load speed.



STEERING AXLE (pneumatic shown)

■ Rugged Design

- Linkage pivot pins have a “double shear” design to withstand impact without loosening or breaking.

■ Simple Axle Design

- Double-ended cylinder provides steering force.



DASH DISPLAY

■ Microprocessor

- Monitors the condition of truck systems as well as controlling their functions.
- Controls neutral starting and prevents cranking while the engine is running.

■ Gauges

- Engine coolant temperature.
- Fuel level for Diesel.

■ LCD Display

- Hourmeter and maintenance interval are displayed on the LCD screen.

■ LED Lights Indicate

- High transmission temperature • Low engine oil pressure
- Alternator charge • Fuel system malfunction
- Park brake applied • Maintenance required • Seat belt

■ Push Switches

- Headlight and optional worklights are controlled with push switches.

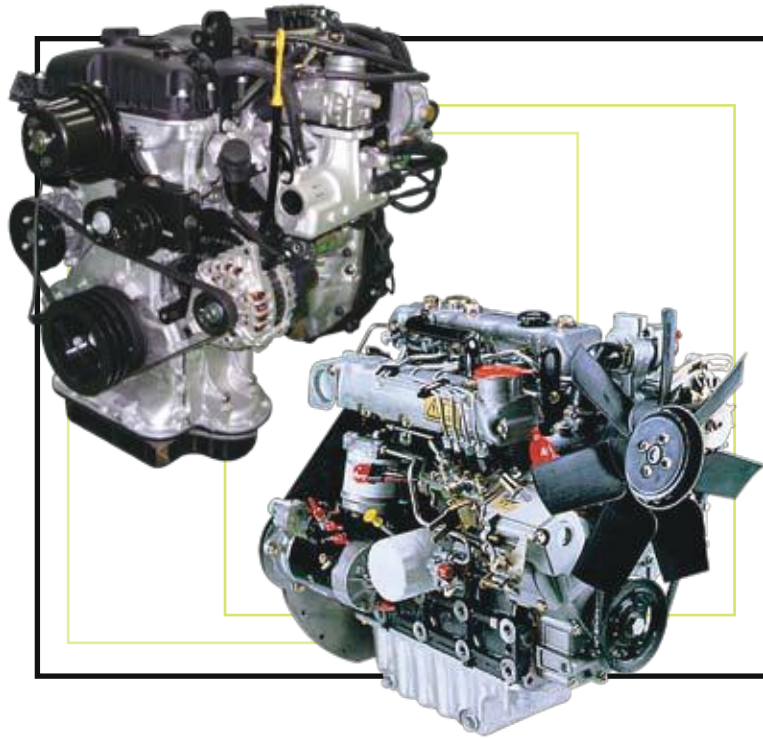

THE POWER BEHIND THE PUNCH

■ High-Performance Hyundai Theta LPG Engine

- The 4-cylinder, dual overhead cam engine produces 52 HP and 114 ft-lbs of torque @ 1500 rpm for superior performance.
- Internal, self-lubricating chain-driven cams and automatic chain tensioner provide long-life and protection from debris.

■ Recognized Worldwide Yanmar Diesel Engine

- Durable, easy to start, low-smoke, easy to service.
- High pressure indirect-injection = better fuel economy.
- Vertical exhaust is standard equipment.

■ EPA and CARB Compliant

- Hyundai engine meets ultra-low emission requirements.
- Yanmar engine meets low-emission & low particulate requirements.



RUGGED UPRIGHT AND CARRIAGE

■ I-Channel Construction

- Maximizes visibility and stiffness, allows for internal hosing and cable.
- Six carriage rollers and two side-thrust rollers minimize deflection and sideplay, reduce roller contact stress and extend component life.
- Hydraulic cushioning valves provide silent staging of the rails to reduce shock during both lifting and lowering.

■ Shimmable, Sealed & Canted Load Rollers

- Maximize Load Distribution & Reduce Free Play.

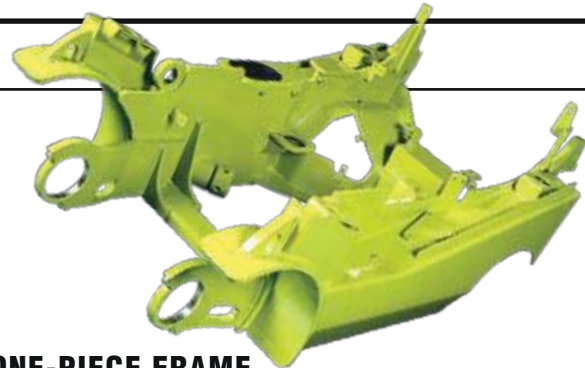

ONE-PIECE FRAME

- Heavy duty, welded, and formed steel plate design protects from impact damage and extends the life of the truck.
- An integral hydraulic sump, with remote breather provides cooling for hydraulics in tough applications.

Available Equipment

- Mirrors
- Sideshifters
- Strobe lights
- Backup alarm
- Rear work light
- Auxiliary valves
- Turn signal lights
- Hose adaptations
- Combination stop/tail/backup lights
- Hydraulic control options
- Bottler's tilt
- Tire options
- Travel speed limit
- Convenience console
- Air cleaner safety element
- Pre-cleaner, overhead guard mounted
- U.L. Type LPS construction
- Suspension seat, vinyl and cloth
- Reduced height overhead guard
- Swing-down LPG tank bracket



OPERATOR COMPARTMENT

■ Optional Fully Adjustable Seat

- 2.4" Vertical Travel • 20° Backrest Adjustment Range
- 6" fore / aft adjustment • Contoured for support
- Non-Cinching, Retractable Seat Belt

■ Thick Molded Floor Mat

- Reduces vibration and noise level.
- Improves operator comfort.

■ Minimal Arm Fatigue

- Electronic directional controls enable true fingertip operation.

■ Tilt Steering Column

- Adjusts to Suit Operator & Easier Entry/Exit.

GENERAL DATA & STANDARD DIMENSIONS

Upright Table

Maximum ¹ Fork Height in mm	Overall Height Lowered in mm	Free Lift ³ w/o LBR in mm	Standard ² Tilt Spec B°/F°
C15/18/20sC Standard			
89 2265	67 1693	4.3 110	8/8
100 2545	72 1833	4.3 110	8/8
110 2795	77 1958	4.3 110	8/8
121 3085	83 2103	4.3 110	8/8
• 129 3285	87 2203	4.3 110	8/8
143 3640	94 2380	4.3 110	8/8
160 4070	104 2653	4.3 110	5/6
172 4365	112 2853	4.3 110	5/6
183 4655	120 3048	4.3 110	5/6
203 5145	133 3378	4.3 110	4/3

Maximum ¹ Fork Height in mm	Overall Height Lowered in mm	Free Lift ³ w/o LBR in mm	Standard ² Tilt Spec B°/F°
C15/18/20sC Triple Stage			
156 3970	72 1833	49 1201	5/6
171 4345	77 1958	54 1326	5/6
• 188 4780	83 2103	59 1471	5/6
204 5185	89 2253	65 1621	4/3
213 5400	92 2343	69 1711	4/3
219 5565	95 2413	72 1781	4/3
225 5720	98 2478	74 1846	4/3
237 6015	102 2603	79 1971	4/3
255 6470	110 2793	87 2161	2/0
279 7075	120 3048	97 2416	2/0

Maximum ¹ Fork Height in mm	Overall Height Lowered in mm	Free Lift ³ w/o LBR in mm	Standard ² Tilt Spec B°/F°
C15/18/20sC Hi-Lo			
115 2925	77 1955	54 1323	8/8
• 127 3215	83 2115	60 1483	8/8
138 3515	89 2255	65 1623	8/8
145 3695	95 2405	71 1773	8/8
150 3810	98 2480	74 1848	8/8

* Indicates Common Preferred Spec
¹ For overall height raised with load backrest, add 48 in. (1220 mm) to maximum fork height.
² Standard tilt shown. Contact Clark representative for information on optional tilt.
³ Freelif dimensions shown are without load backrest.

Other uprights available, contact a Clark representative.

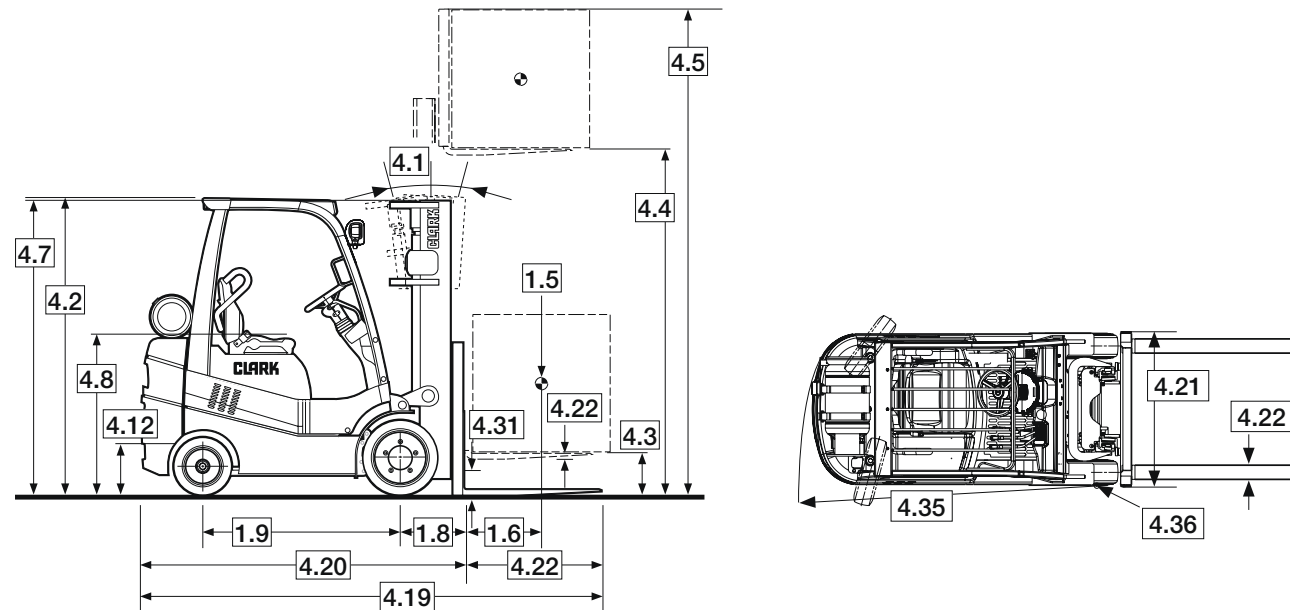

For corresponding data see Specification Chart

Notes

Production engines and driveline components may vary in output and/or efficiency by ±5%. The performance shown represents nominal values which may be obtained under typical operating conditions of a machine.

ANSI/ITSDF and Insurance Classification

Standard truck meets all applicable mandatory requirements of Part III-ANSI/ITSDF B56.1 Safety Standard for Powered Industrial Trucks and Underwriters Laboratories requirements as to fire hazard only for D and LP classifications. For further information contact a Clark representative.

Users should be aware of, and adhere to, applicable codes and regulations regarding operator training, use, operation and maintenance of powered industrial trucks, including:

- ANSI/ITSDF B56.1
- NFPA 505, fire safety standard for powered industrial trucks - type designations, areas of use, maintenance and operation.
- Occupational Safety and Health Administration (OSHA) regulations that may apply.

Contact your authorized CLARK forklift truck dealer for further information including operator training programs and auxiliary visual and audible warning systems, fire extinguishers, etc., as available for specific user applications and requirements.

Specifications, equipment, technical data, photos and illustrations are based on information at time of printing and are subject to change without notice. Some products may be shown with optional equipment.

Upright Table

Maximum ¹ Fork Height in mm	Overall Height Lowered in mm	Free Lift ³ w/o LBR in mm	Standard ² Tilt Spec B°/F°
C15/18/20s Standard			
89 2265	68 1730	4.3 110	8/8
100 2545	74 1870	4.3 110	8/8
110 2795	79 1995	4.3 110	8/8
121 3085	84 2140	4.3 110	8/8
• 129 3285	88 2240	4.3 110	8/8
143 3640	95 2417	4.3 110	8/8
160 4070	106 2690	4.3 110	5/6
172 4365	114 2890	4.3 110	5/6
183 4655	121 3085	4.3 110	5/6
203 5145	134 3415	4.3 110	5/3

Maximum ¹ Fork Height in mm	Overall Height Lowered in mm	Free Lift ³ w/o LBR in mm	Standard ² Tilt Spec B°/F°
C15/18/20s Triple Stage			
156 3970	74 1870	49 1238	5/6
171 4345	79 1995	54 1363	5/6
• 188 4780	84 2140	59 1508	5/6
204 5185	90 2290	65 1658	5/3
213 5400	94 2380	69 1748	5/3
219 5565	96 2450	72 1818	5/3
225 5720	99 2515	74 1883	5/3
237 6015	104 2640	79 2008	5/3
255 6470	111 2830	87 2198	3/0
279 7075	121 3085	97 2453	3/0

Maximum ¹ Fork Height in mm	Overall Height Lowered in mm	Free Lift ³ w/o LBR in mm	Standard ² Tilt Spec B°/F°
C15/18/20s Hi-Lo			
115 2925	79 2005	55 1389	8/8
• 127 3215	85 2165	61 1549	8/8
138 3515	91 2305	66 1689	8/8
145 3695	97 2455	72 1839	8/8
150 3810	100 2530	75 1914	8/8

* Indicates Common Preferred Spec
¹ For overall height raised with load backrest, add 48 in. (1220 mm) to maximum fork height.
² Standard tilt shown. Contact Clark representative for information on optional tilt.
³ Freelif dimensions shown are without load backrest.

Other uprights available, contact a Clark representative.

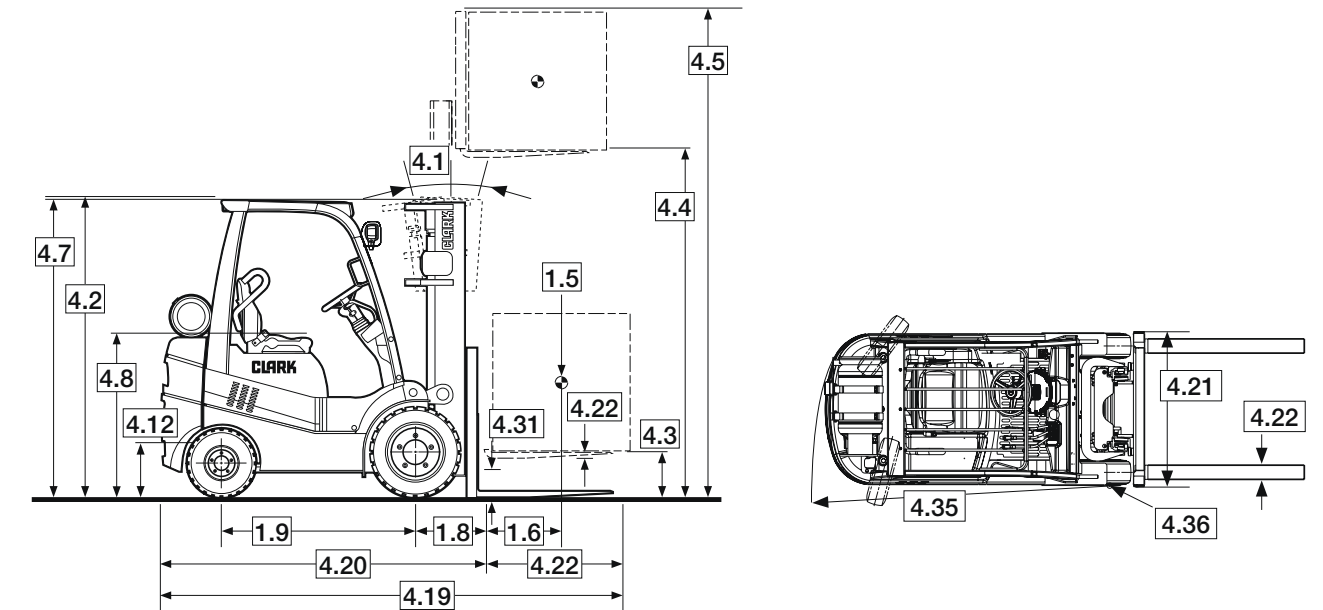

For corresponding data see Specification Chart

STANDARD SPECIFICATIONS

C15/18/20sC

Specifications	1.1	Manufacturer		Clark	Clark	Clark	Clark	Clark	Clark
	1.2	Manufacturer's Designation		C15CL	C18CL	C20sCL	C15L	C18L	C20sL
	1.3	Drive unit Diesel, L.P. Gas		LPG	LPG	LPG	LPG	LPG	LPG
	1.4	Operator type stand on / driver seated		Rider-Seated	Rider-Seated	Rider-Seated	Rider-Seated	Rider-Seated	Rider-Seated
	1.5	Load capacity / rated load	lbs(kg)	3000 (1500)	3500 (1800)	4000 (2000)	3000 (1500)	3500 (1800)	4000 (2000)
	1.6	Load center distance	in(mm)	24 (500)	24 (500)	24 (500)	24 (500)	24 (500)	24 (500)
	1.8	Load center distance, center of drive axle to fork face	in(mm)	STD 14.7 (375) TSU 14.9 (378)	STD 14.7 (375) TSU 14.9 (378)	STD 14.7 (375) TSU 14.9 (378)	STD 15.4 (392) TSU 15.5 (395)	STD 15.4 (392) TSU 15.5 (395)	STD 15.4 (392) TSU 15.5 (395)
	1.9	Wheelbase	in(mm)	48.0 (1220)	48.0 (1220)	48.0 (1220)	55.1 (1400)	55.1 (1400)	55.1 (1400)
	Weight	2.1	Service weight	lbs(kg)	STD 6056 (2746) TSU 6424 (2913)	STD 6529 (2962) TSU 6897 (3129)	STD 6842 (3104) TSU 7210 (3271)	STD 6140 (2785) TSU 6507 (2952)	STD 6633 (3009) TSU 7001 (3176)
2.2		Axle loading, loaded front / rear	lbs(kg)	STD 7985/1071 (3740/507) TSU 8438/986 (3847/463)	STD 8733/1296 (4210/552) TSU 9188/1209 (4053/473)	STD 9526/1316 (4507/598) TSU 9984/1226 (4172/496)	STD 7960/1180 (3733/552) TSU 8397/1110 (3933/519)	STD 8690/1443 (4166/643) TSU 9128/1373 (4100/573)	STD 9458/1499 (4449/707) TSU 9890/1435 (4210/610)
2.3		Axle loading, unloaded front / rear	lbs(kg)	STD 2566/3490 (1164/1583) TSU 3007/3417 (1364/1550)	STD 2411/4118 (1094/1868) TSU 2852/4045 (1294/1835)	STD 2301/4541 (1044/2060) TSU 2742/4468 (1244/2027)	STD 2815/3325 (1277/1508) TSU 3247/3260 (1473/1479)	STD 2687/3946 (1219/3946) TSU 3119/3882 (1415/1761)	STD 2590/4367 (1175/1981) TSU 3022/4303 (1371/1952)
Tires	3.1	Tire type, P = pneumatic, SE = solid pneu, C = cushion		Cushion	Cushion	Cushion	Pneumatic	Pneumatic	Pneumatic
	3.2	Tire size, front	in	18x6x12.125	18x6x12.125	18x6x12.125	6.50x10-12PR	6.50x10-12PR	6.50x10-12PR
	3.3	Tire size, rear	in	14x4.5x8	14x4.5x8	14x4.5x8	5.00x8-10PR	5.00x8-10PR	5.00x8-10PR
	3.5	Wheels, number front / rear (x = drive wheels)		2X/2	2X/2	2X/2	2X/2	2X/2	2X/2
	3.6	Tread, front	in(mm)	31.1 (789)	31.1 (789)	31.1 (789)	35.0 (890)	35.0 (890)	35.0 (890)
	3.7	Tread, rear	in(mm)	32.4 (822)	32.4 (822)	32.4 (822)	35.0 (890)	35.0 (890)	35.0 (890)
	Dimensions	4.1	Tilt of upright / fork carriage, back / forward, a / b	degrees	STD 8/8 TSU 5/6	STD 8/8 TSU 5/6	STD 8/8 TDU 5/6	STD 8/8 TSU 5/6	STD 8/8 TSU 5/6
4.2		Height, upright lowered	in(mm)	STD 86.7 (2203) TSU 82.8 (2103)	STD 86.7 (2203) TSU 82.8 (2103)	STD 86.7 (2203) TSU 82.8 (2103)	STD 88.1 (2240) TSU 84.2 (2140)	STD 88.1 (2240) TSU 84.2 (2140)	STD 88.1 (2240) TSU 84.2 (2140)
4.3		Freelift	in(mm)	STD 4.3 (110) TSU 57.9 (1471)	STD 4.3 (110) TSU 57.9 (1471)	STD 4.3 (110) TSU 57.9 (1471)	STD 4.3 (110) TSU 59.3 (1508)	STD 4.3 (110) TSU 59.3 (1508)	STD 4.3 (110) TSU 59.3 (1508)
4.4		Lift height	in(mm)	STD 129 (3285) TSU 188 (4780)	STD 129 (3285) TSU 188 (4780)	STD 129 (3285) TSU 188 (4780)	STD 129 (3285) TSU 188 (4780)	STD 129 (3285) TSU 188 (4780)	STD 129 (3285) TSU 188 (4780)
4.5		Height, upright extended	in(mm)	STD 177.0 (4496) TSU 236.0 (5994)	STD 177.0 (4496) TSU 236.0 (5994)	STD 177.0 (4496) TSU 236.0 (5994)	STD 177 (4496) TSU 236 (5994)	STD 177 (4496) TSU 236 (5994)	STD 177 (4496) TSU 236 (5994)
4.7		Height overhead guard	in(mm)	81.1 (2060)	81.1 (2060)	81.1 (2060)	83.5 (2120)	83.5 (2120)	83.5 (2120)
4.8		Seat height	in(mm)	40.2 (1021)	40.2 (1021)	40.2 (1021)	42.2 (1072)	42.2 (1072)	42.2 (1072)
4.12		Coupling height	in(mm)	10.25 (260)	10.25 (260)	10.25 (260)	11.5 (292)	11.5 (292)	11.5 (292)
4.19		Overall length	in(mm)	STD 122.0 (3099) TSU 122.2 (3104)	STD 123.6 (3139) TSU 123.8 (3145)	STD 124.7 (3167) TSU 124.9 (3173)	STD 128.4 (3261) TSU 128.5	STD 130.2 (3307) TSU 130.3 (3310)	STD 131.9 (3350) TSU 132.0 (3353)
4.20		Length to face of forks	in(mm)	STD 80.0 (2033) TSU 80.2 (2036)	STD 81.6 (2075) TSU 81.8 (2078)	STD 82.7 (2103) TSU 82.9 (2106)	STD 86.4 (2196) TSU 86.5 (2199)	STD 88.2 (2241) TSU 88.3 (2244)	STD 89.9 (2283) TSU 90.0 (2286)
4.21		Width	in(mm)	37.0 (940)	37.0 (940)	37.0 (940)	42.1 (1070)	42.1 (1070)	42.1 (1070)
4.22		Fork dimensions	in(mm)	1.5x4x42 (40x100x1070)	1.5x4x42 (40x100x1070)	1.5x4x42 (40x100x1070)	1.5x4x42 (40x100x1070)	1.5x4x42 (40x100x1070)	1.5x4x42 (40x100x1070)
4.23		Fork carriage		Hook Type	Hook Type	Hook Type	Hook Type	Hook Type	Hook Type
4.24		Fork carriage width	in(mm)	33.0 (838)	33.0 (838)	33.0 (838)	41.0 (1042)	41.0 (1042)	41.0 (1042)
4.31		Ground clearance minimum, loaded	in(mm)	3.2 (82)	3.2 (82)	3.2 (82)	4.72 (120)	4.72 (120)	4.72 (120)
4.32		Ground clearance center of wheelbase	in(mm)	5.0 (127)	5.0 (127)	5.0 (127)	4.8 (124)	4.8 (124)	4.8 (124)
4.34		Right Angle Slack (add load length and clearance)	in(mm)	STD 85.2 (2167) TSU 85.4 (2170)	STD 87.2 (2215) TSU 87.4 (2218)	STD 88.2 (2241) TSU 88.4 (2244)	STD 97.0 (2465) TSU 97.1 (2468)	STD 98.9 (2513) TSU 99.0 (2516)	STD 100.2 (2546) TSU 100.3 (2549)
4.35		Outside turning radius	in(mm)	70.5 (1792)	72.5 (1840)	73.5 (1866)	81.6 (2073)	83.5 (2121)	84.8 (2154)
4.36		Inside turning radius	in(mm)	3.5 (90)	3.3 (83)	3.3 (83)	11.22 (285)	11.22 (285)	11.22 (285)
Performance		5.1	Travel speed loaded / unloaded	mph(km/h)	10.4 / 10.5 (16.7 / 16.9)	10.4 / 10.5 (16.7 / 16.9)	10.4 / 10.5 (16.7 / 16.9)	13.3 / 13.5 (21.4 / 21.7)	13.3 / 13.5 (21.4 / 21.7)
	5.2	Lift speed loaded / unloaded	fpm(ms)	STD 132/134 (0.67/0.68) TSU 126/128 (0.64/0.65)	STD 130/134 (0.66/0.68) TSU 124/128 (0.63/0.65)	STD 128/1134 (0.65/0.68) TSU 124/128 (0.63/0.65)	STD 132/134 (0.67/0.68) TSU 126/128 (0.64/0.65)	STD 130/134 (0.66/0.68) TSU 124/128 (0.63/0.65)	STD 128/134 (0.65/0.68) TSU 122/128 (0.62/0.65)
	5.3	Lowering speed loaded / unloaded	fpm(ms)	STD 88/82 (0.45/0.42) TSU 84/79 (0.43/0.40)	STD 88/82 (0.45/0.42) TSU 84/79 (0.43/0.40)	STD 88/82 (0.45/0.42) TSU 84/79 (0.43/0.40)	STD 88/82 (0.45/0.42) TSU 84/79 (0.43/0.40)	STD 88/82 (0.45/0.42) TSU 84/79 (0.43/0.40)	STD 88/82 (0.45/0.42) TSU 84/79 (0.43/0.40)
	5.6	Max. drawbar pull loaded ¹	lbs(N)	4280 (19040)	4658 (20720)	5063 (22521)	4117 (18313)	4110 (18282)	4106 (18264)
	5.8	Max. gradeability loaded / unloaded ¹	%	39.1 / 19.2	38.6 / 16.7	38.9 / 15.2	39.8 / 21.3	39.1 / 18.8	38.9 / 17.2
	5.10	Service brake		Drum	Drum	Drum	Drum	Drum	Drum
Drive Line	7.1	Manufacturer / Type		Hyundai Theta 2.4	Hyundai Theta 2.4	Hyundai Theta 2.4	Hyundai Theta 2.4	Hyundai Theta 2.4	Hyundai Theta 2.4
	7.2	Rated output per SAE J1349	HP/kW @ rpm	52 / 38.8 @ 2650	52 / 38.8 @ 2650	52 / 38.8 @ 2650	52 / 38.8 @ 2650	52 / 38.8 @ 2650	52 / 38.8 @ 2650
	7.3	Rated speed	rpm	2650	2650	2650	2650	2650	2650
	7.4	No. of cylinders / displacement	# / cu. in. (Liters)	4 / 146 (2.4)	4 / 146 (2.4)	4 / 146 (2.4)	4 / 146 (2.4)	4 / 146 (2.4)	4 / 146 (2.4)
8.2	Operating pressure for attachments	psi/bar	2030 / 140	2030 / 140	2030 / 140	2030 / 140	2030 / 140	2030 / 140	
8.4	Sound level, driver's ear	dB(A)	80	80	80	79	79	79	

Notes: ¹ Assumes Traction Coefficient of .6

C15/18/20s

Clark	Clark	Clark
C15D	C18D	C20sD
Diesel	Diesel	Diesel
Rider-Seated	Rider-Seated	Rider-Seated
3000 (1500)	3500 (1800)	4000 (2000)
24 (500)	24 (500)	24 (500)
STD 15.4 (392) TSU 15.5 (395)	STD 15.4 (392) TSU 15.5 (395)	STD 15.4 (392) TSU 15.5 (395)
55.1 (1400)	55.1 (1400)	55.1 (1400)
STD 6140 (2785) TSU 6507 (2952)	STD 6633 (3009) TSU 7001 (3176)	STD 6957 (3156) TSU 7325 (3323)
STD 7960/1180 (3733/552) TSU 8397/1110 (3933/519)	STD 8690/1443 (4166/643) TSU 9128/1373 (4100/573)	STD 9458/1499 (4449/707) TSU 9890/1435 (4210/610)
STD 2815/3325 (1277/1508) TSU 3247/3260 (1473/1479)	STD 2687/3946 (1219/3946) TSU 3119/3882 (1415/1761)	STD 2590/4367 (1175/1981) TSU 3022/4303 (1371/1952)
Pneumatic	Pneumatic	Pneumatic
6.50x10-12PR	6.50x10-12PR	6.50x10-12PR
5.00x8-10PR	5.00x8-10PR	5.00x8-10PR
2X/2	2X/2	2X/2
35.0 (890)	35.0 (890)	35.0 (890)
35.0 (890)	35.0 (890)	35.0 (890)
STD 8/8 TSU 5/6	STD 8/8 TSU 5/6	STD 8/8 TSU 5/6
STD 88.1 (2240) TSU 84.2 (2140)	STD 88.1 (2240) TSU 84.2 (2140)	STD 88.1 (2240) TSU 84.2 (2140)
STD 4.3 (110) TSU 59.3 (1508)	STD 4.3 (110) TSU 59.3 (1508)	STD 4.3 (110) TSU 59.3 (1508)
STD 129 (3285) TSU 188 (4780)	STD 129 (3285) TSU 188 (4780)	STD 129 (3285) TSU 188 (4780)
STD 177 (4496) TSU 236 (5994)	STD 177 (4496) TSU 236 (5994)	STD 177 (4496) TSU 236 (5994)
83.5 (2120)	83.5 (2120)	83.5 (2120)
42.2 (1072)	42.2 (1072)	42.2 (1072)
11.5 (292)	11.5 (292)	11.5 (292)
STD 128.4 (3261) TSU 128.5	STD 130.2 (3307) TSU 130.3 (3310)	STD 131.9 (3350) TSU 132.0 (3353)
STD 86.4 (2196) TSU 86.5 (2199)	STD 88.2 (2241) TSU 88.3 (2244)	STD 89.9 (2283) TSU 90.0 (2286)
42.1 (1070)	42.1 (1070)	42.1 (1070)
1.5x4x42 (40x100x1070)	1.5x4x42 (40x100x1070)	1.5x4x42 (40x100x1070)
Hook Type	Hook Type	Hook Type
41.0 (1042)	41.0 (1042)	41.0 (1042)
4.72 (120)	4.72 (120)	4.72 (120)
4.8 (124)	4.8 (124)	4.8 (124)
STD 97.0 (2465) TSU 97.1 (2468)	STD 98.9 (2513) TSU 99.0 (2516)	STD 100.2 (2546) TSU 100.3 (2549)
81.6 (2073)	83.5 (2121)	84.8 (2154)
11.22 (285)	11.22 (285)	11.22 (285)
10.7 / 11.1 (17.2 / 17.9)	10.9 / 11.1 (17.6 / 17.9)	10.8 / 11.2 (17.4 / 18.1)
STD 132/134 (0.67/0.68) TSU 126/128 (0.64/0.65)	STD 130/134 (0.66/0.68) TSU 124/128 (0.63/0.65)	STD 128/134 (0.65/0.68) TSU 122/128 (0.62/0.65)
STD 88/82 (0.45/0.42) TSU 84/79 (0.43/0.40)	STD 88/82 (0.45/0.42) TSU 84/79 (0.43/0.40)	STD 88/82 (0.45/0.42) TSU 84/79 (0.43/0.40)
3359 (14945)	3375 (15014)	3390 (15083)
37.5 / 20.9	33.2 / 18.6	31.3 / 17.1
Drum	Drum	Drum
Yanmar 4TNV88	Yanmar 4TNV88	Yanmar 4TNV88
38.6 (28.8) @ 2400	38.6 (28.8) @ 2400	38.6 (28.8) @ 2400
2600	2600	2600
4 / 134 (2.2)	4 / 134 (2.2)	4 / 134 (2.2)
2030 (140)	2030 (140)	2030 (140)
81	81	81

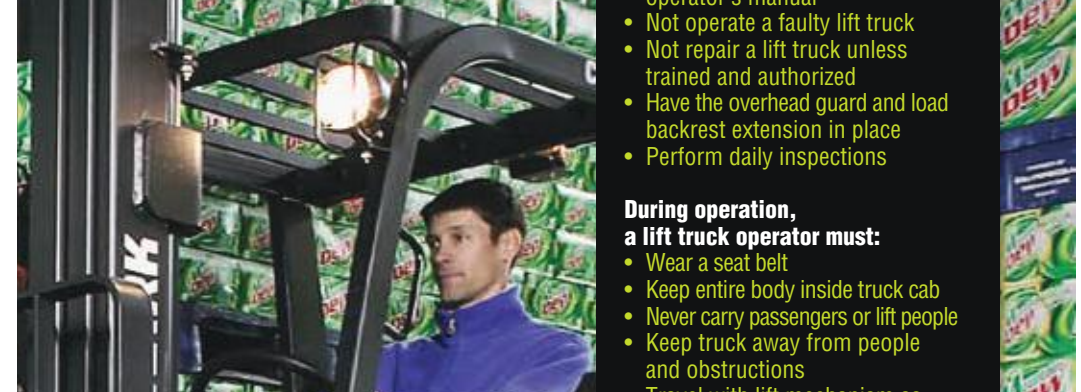
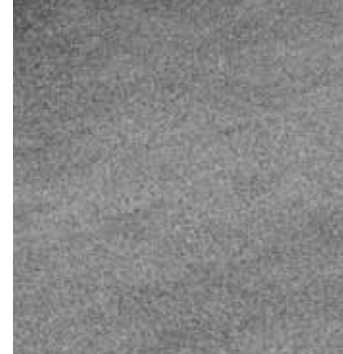

& Don't Forget... Safety Starts With You!

Before operating a lift truck, an operator must:

- Be trained and authorized
- Read and understand operator's manual
- Not operate a faulty lift truck
- Not repair a lift truck unless trained and authorized
- Have the overhead guard and load backrest extension in place
- Perform daily inspections

During operation, a lift truck operator must:

- Wear a seat belt
- Keep entire body inside truck cab
- Never carry passengers or lift people
- Keep truck away from people and obstructions
- Travel with lift mechanism as low as possible and tilted back
- Allow safe stopping distance and come to a complete stop before leaving operator compartment

To park a lift truck, an operator must:

- Completely lower forks or attachments
- Shift into neutral
- Turn key off
- Set parking brake

- We don't just build forklifts. As a company, we are also focused on providing our customers with the best possible technical service support and aftermarket parts available.
- Even though our business starts with a quality, cost-effective product, our organization understands that it is the support and services we provide after the sale that help keep your business running at peak efficiency.
- **THE CLARK PartsPRO® SYSTEM** is our industry-leading electronic parts and service documentation tool that provides dealers with a quick and accurate method of identifying parts for every CLARK forklift built since 1961. PartsPRO® ensures the availability of the most current technical information and has the unique capability to create parts manuals specific to your mixed CLARK fleet, making it simple to positively identify and order the correct part(s) from your local CLARK dealer. The right CLARK part — The First Time, Every Time.
- **UNRIVALED PARTS SUPPORT** Our Aftermarket Distribution Center provides parts to over 250 North American CLARK dealers and many international dealers. This CLARK operated 184,000 square foot facility is dedicated to supporting the CLARK models built over the last 90 years. This facility is focused on providing excellent off-the-shelf availability, quality parts, quick response time and competitive pricing.

DEPENDABLE PARTS = DEPENDABLE TRUCKS

To Find Your Nearest Authorized CLARK Dealer, Visit Our Website www.clarkmhc.com



BUILT TO LAST.®



CLARK MATERIAL HANDLING COMPANY

North American Headquarters
700 Enterprise Drive • Lexington, KY 40510
866-252-5275 • www.clarkmhc.com

C15/18/20sC & C15/18/20s
59-894-0427 Printed in USA CR061010M

© 2010 CLARK Material Handling Company