

H800AJ HYBRID

ARTICULATING BOOM LIFT



Preliminary Specifications

Performance

Platform Height	80 ft	24.38 m
Horizontal Outreach	51 ft 10 in.	15.8 m
Up and Over Height	32 ft 1 in.	9.78 m
Swing	360 Degrees Continuous	
Platform Capacity	500 lb	227 kg
Platform Rotator	180 Degrees Hydraulic	
Jib Range of Articulation	130 Degrees (+70, -60)	
Weight	35,400 lb	16,057 kg
Drive Speed 4WD	3.0 mph	4.8 km/h
Gradeability 4WD	45%	
Axle Oscillation	8 in.	204 cm
Turning Radius Inside/Outside		
2WS	12 ft./22 ft. 6 in.	3.66 m/6.86 m
4WS	7 ft./14 ft. 6 in.	2.13 m/4.42 m

Standard Specifications

Power Source

Diesel Engine		
Kubota Tier 4 Final	25 hp	18.6 kW
Motor/Generator Power	30 hp	22.3 kW
Fuel Tank Capacity	30 gal.	113.6 L
Batteries	12V 205 AH Maintenance free AGM	
System Voltage	84V	
Battery Quantity	14	

Hydraulic System

• Capacity	30.6 gal.	115.8 L
• Auxiliary Power	12V DC	

Tires

• Standard	15-625 Wide Lug Tread
• Optimal	18 x 19.5 Foam-Filled

Standard Features

- Oscillating Axle
- 180 Degree Hydraulic Platform Rotator
- 110V-AC Receptacle in the Platform
- 5 Degree Tilt Alarm/Indicator Light
- Automatic Engine Idle, Start/Stop
- Automatic Battery Charger in Hybrid Mode
- Electric Only Capability
- Swing-Out Engine Tray
- 12V-DC Auxiliary Power
- Hourmeter
- Horn
- Control ADE® System
- Proportional Controls
- Gull-Wing Engine Hood
- Platform Console Machine Status Light Panel*
- Lifting/Tie Down Lugs
- All Motion Alarm
- Glow Plugs (Diesel Engines)

* Provides indicator lights at platform control console for system distress, 5 degree tilt light, and foot switch status.



Accessories & Options

- Platform: 36 x 72 in. (0.91 x 1.83 m)
- Fall Arrest Platform, Rear Entry¹: 36 x 96 in. (0.91 x 2.44 m)
- Self-Closing Gate
- Mesh to Top Rail—Bolt-on Aluminum
- Soft Touch System
- Operator Tool Tray
- 1/2 in. Airline to Platform
- Exhaust Purifier Muffler (Diesel)
- Cold Weather Start Kit²
- Hostile Environment Kit³
- Light Package⁴
- Platform Worklights
- Flashing Amber Beacon
- Accessory Packages:
 - SkyPower®
 - SkyWelder®
 - SkyGlazier®
 - SkyCutter®
 - Pipe Rack
 - SkyWelder®/ SkyCutter® Combination

1. Foam-filled tires required.
2. Includes glow plugs (Diesel), battery heater, oil tank heater.
3. Includes console cover, boom wipers and cylinder bellows.
4. Includes head and tail lights, and platform worklights.

Note: Some options may increase lead time, and some option combinations may not be available.

H800AJ HYBRID

ARTICULATING BOOM LIFT



All dimensions are approximate.

H800AJ

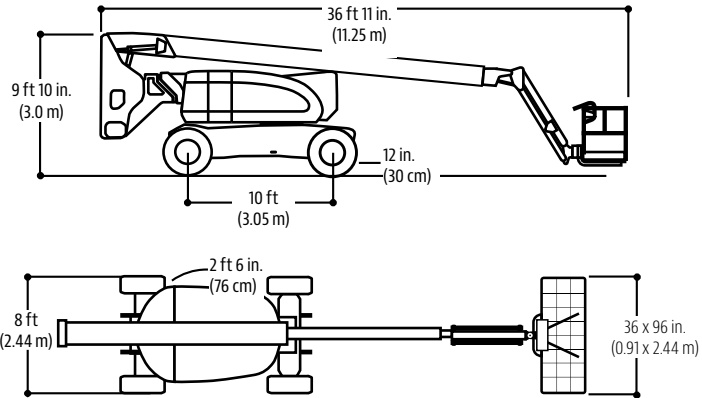

Reach Diagram

H800AJ

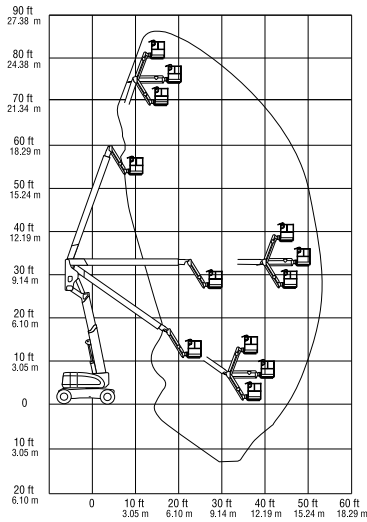

The JLG "1 & 5" Warranty

JLG Industries, Inc. backs its products with its exclusive "1 & 5" Warranty. We provide coverage on all products for one (1) full year, and cover all specified major structural components for five (5) years. Due to continuous product improvements, we reserve the right to make specification and/or equipment changes without prior notification. This machine meets or exceeds applicable OSHA Regulations in 29 CFR 1910.67, 29 CFR 1926.453, ANSI A92.5-2006, and CSA Standard CAN3-B354.2-M82, as originally manufactured for intended applications.

Part No.: 3131123
Printed in USA

JLG Industries, Inc.
1 JLG Drive
McConnellsburg, PA 17233-9533
Telephone 717-485-5161
Toll-free in US 877-JLG-LIFT
Fax 717-485-6417
www.jlg.com

An Oshkosh Corporation Company