

GC15S-9 / GC18S-9 / GC20SC-9
GC20S-9 / GC25S-9 / GC30S-9 / GC33S-9
GC35S-9 / GC35S-9 BCS / GC45S-9 / GC45S-9 BCS / GC55C-9 / GC55C-9 BCS



9 SERIES FORKLIFTS

Internal Combustion Cushion Tire Forklifts

3,000 lb. to 12,000 lb. Capacity



TECHNICAL DATA

Characteristics	1.1	Manufacturer			Doosan	Doosan	Doosan	
	1.2	Model Designation			GC15S-9	GC18S-9	GC20SC-9	
	1.3	Drive: Diesel, Gasoline, LP			LP	LP	LP	
	1.4	Operator Type: Seated			Seated	Seated	Seated	
	1.5	Load Capacity	Q	lb(kg)	3,000 (1,340)	3,500 (1,560)	4,000(1,785)	
	1.6	Load Center	c	in(mm)	24 (610)	24 (610)	24(610)	
	1.8	Load Distance: Center of Driveaxle to Fork	x	in(mm)	15.5 (394)	15.5 (394)	15.7(399)	
	1.9	Wheelbase	y	in(mm)	50.6 (1,285)	50.6 (1,285)	50.6(1,285)	
	Weight	2.1	Service Weight		lb(kg)	6,038 (2,739)	6,460 (2,930)	6,903(3,131)
2.2		Axle Loading, Loaded Front/Rear		lb(kg)	7,529/1,462 (3,415/663)	8,393/1,504 (3,807/682)	9,292/1,545 (4,215/701)	
2.3		Axle Loading, UnLoaded Front/Rear		lb(kg)	2,266/3,770 (1,028/1,710)	2,266/4,191 (1,028/1,901)	2,266/4,634 (1,028/2,102)	
Tires	3.1	Tires: Pneumatic (P), Cushion (C)			C	C	C	
	3.2	Tire size, Front			18 x 6 x 12.12	18 x 6 x 12.12	18 x 6 x 12.12	
	3.3	Tire size, Rear			14 x 5 x 10	14 x 5 x 10	14 x 5 x 10	
	3.5	Wheels, number Front/Rear			2/2	2/2	2/2	
	3.6	Tread, Front	b11	in(mm)	31.0 (786)	31.0 (786)	31.0 (786)	
	3.7	Tread, Rear	b12	in(mm)	32.0 (814)	32.0 (814)	32.0 (814)	
	Dimensions	4.1	Tilt of Mast Forward/Backward	a/b	°	6/8	6/8	6/8
4.2		Height, Mast lowered	h1	in(mm)	78.0 (1,980)	78.0 (1,980)	78.0 (1,980)	
4.3		Free Lift	h2	in(mm)	5.1 (130)	5.1 (130)	5.3 (135)	
4.4		Max Fork Height	h3	in(mm)	118.0 (3,000)	118.0 (3,000)	118.0 (3,000)	
4.5		Height, Mast Extended	h4	in(mm)	159.3 (4,045)	159.3 (4,045)	159.4 (4,050)	
4.7		Height of Overhead Guard(Cabin)	h6	in(mm)	81.0 (2,060)	81.0 (2,060)	81.0 (2,060)	
4.8		Height of Seat	h7	in(mm)	41.5 (1,055)	41.5 (1,055)	41.5 (1,055)	
4.19		Overall Length	l1	in(mm)	124.1 (3,152)	124.9 (3,173)	127.1 (3,228)	
4.20		Length to Forkface	l2	in(mm)	82.8 (2,102)	83.6 (2,123)	85.7 (2,178)	
4.21		Overall Width	b1/b2	in(mm)	37.0 (940)	37.0 (940)	37.0 (940)	
4.22		Fork Dimensions	s/e/l	in (mm)	1.4x4x41 (35x100x1,050)	1.4x4x41 (35x100x1,050)	1.4x4x41 (35x100x1,050)	
4.23		Fork Carriage ISO 2328, Class/Type A,B			II/A	II/A	II/A	
4.24		Fork Carriage Width	b3	in(mm)	37.0 (940)	37.0 (940)	37.0 (940)	
4.31		Ground Clearance, Loaded (Below Mast)	m1	in(mm)	3.0 (75)	3.0 (75)	3.0 (75)	
4.32		Ground Clearance, Center of Wheelbase	m2	in(mm)	4.1 (105)	4.1 (105)	4.1 (105)	
4.34.1		Aisle Width for Pallets L=48" x W=40"	Ast	in(mm)	127.6 (3,242)	129.3 (3,284)	130.5 (3,314)	
4.35	Turning Radius	Wa	in(mm)	71.9 (1,826)	73.5 (1,867)	74.4 (1,891)		
4.36	Internal Turning Radius	b13	in(mm)	23.8 (605)	23.8 (605)	23.8 (605)		
Performance Data	5.1	Travel Speed, Loaded/UnLoaded		mph (km/h)	11.1/11.1 (17.8/17.8)	11.1/11.1 (17.8/17.8)	11.1/11.1 (17.8/17.8)	
	5.2	Lift Speed, Loaded/UnLoaded		fpm (m/s)	126/130 (0.64/0.66)	124/130 (0.63/0.66)	122/130 (0.62/0.66)	
	5.3	Lowering Speed, Loaded/UnLoaded		fpm (m/s)	100.4/98.4 (0.51/0.5)	100.4/98.4 (0.51/0.5)	100.4/98.4 (0.51/0.5)	
	5.5	Drawbar pull, Loaded/UnLoaded(@ 1mph)		lb(N)	3,196 (14,225)	3,196 (14,225)	3,196 (14,225)	
	5.6	Max. Drawbar pull, Loaded/UnLoaded		lb(N)	3,636 (16,180)	3,636 (16,180)	3,636 (16,180)	
	5.7	Gradeability, Loaded/UnLoaded(@ 1mph)		%	38.5/69.4	33.0/60.1	31.0/56.1	
	5.8	Max. Gradeability, Loaded/UnLoaded		%	46.8/90.1	39.8/76.0	36.5/70.3	
	5.10	Service Brake			Foot/Hydraulic	Foot/Hydraulic	Foot/Hydraulic	
	Combustion Engine	7.1	Engine Manufacturer/Type			PSI/4G63	PSI/4G63	PSI/4G63
		7.2	Engine Power		hp(kW)	50.6 (37.7)	50.6 (37.7)	50.6 (37.7)
7.3		Rated Speed		min-1	2,450	2,450	2,450	
7.3.1		Torque at 1/min		ft•lbs (N•m)	110@1,800 (148.7@1,800)	110@1,800 (148.7@1,800)	110@1,800 (148.7@1,800)	
7.4		Number of Cylinders/Displacement		-/cc(-/cm3)	4/1,997	4/1,997	4/1,997	
7.10		Battery Voltage/Normal Capacity		V/Ah	12/45	12/45	12/45	
Oth.	10.1	Operating Pressure for Attachments		psi(bar)	2,553 (176)	2,553 (176)	2,553 (176)	
	10.2	Oil Volume for Attachments		gpm(l/min)	13.2 (50)	13.2 (50)	13.2 (50)	

Note: Specification values quoted in this spec sheet have been rounded. Performance may vary due to operating conditions. Products and specifications are subject to improvement and change without prior notice.

Characteristics	1.1	Doosan	Doosan	Doosan	Doosan	Doosan
	1.2	GC20S-9	GC25S-9	GC30S-9	GC33S-9	GC35S-9
	1.3	LP	LP	LP	LP	LP
	1.4	Seated	Seated	Seated	Seated	Seated
	1.5	4,000 (1,800)	5,000 (2,250)	6,000 (2,700)	6,500 (2,950)	8,000 (3,629)
	1.6	24 (610)	24 (610)	24 (610)	24 (610)	24 (610)
	1.8	16.3 (415)	16.3 (415)	16.5 (420)	16.5 (420)	17.6 (447)
	1.9	56.3 (1,430)	56.3 (1,430)	56.3 (1,430)	56.3 (1,430)	61.8 (1,570)
	Weight	2.1	7,400 (3,365)	8,200 (3,715)	9,300 (4,225)	9,750 (4,430)
2.2		9,920/1,480 (4,495/670)	11,450/1,750 (5,185/780)	13,350/1,950 (6,045/880)	14,110/2,140 (6,410/970)	18,043/3,427 (8,184/1,554)
2.3		3,100/4,300 (1,405/1,960)	2,930/5,270 (1,325/2,390)	3,080/6,220 (1,400/2,825)	2,940/6,810 (1,335/3,095)	4,657/8,813 (2,112/3,997)
Tires	3.1	C	C	C	C	C
	3.2	21x7-15	21x7-15	21x8-15	21x8-15	22 x 9 x16
	3.3	16x5-10.5	16x5-10.5	16x6-10.5	16x6-10.5	18 x 7 x 12.2
	3.5	2/2	2/2	2/2	2/2	2/2
	3.6	34.9 (887)	35.9 (912)	35.9 (912)	35.7 (907)	41.0 (1,042)
	3.7	36.0 (915)	36.0 (915)	36.0 (915)	35.0 (890)	41.1 (1,044)
	Dimensions	4.1	6/8	6/8	6/8	6/8
4.2		83.9 (2,130)	83.9 (2,130)	83.9 (2,130)	83.9 (2,130)	84.1 (2,135)
4.3		5.8 (147)	5.8 (147)	6.0 (152)	6.0 (152)	6.3 (160)
4.4		127.0 (3,230)	127 (3,230)	127 (3,230)	127 (3,230)	113.4 (2,880)
4.5		176.4 (4,480)	176.4 (4,480)	176.4 (4,480)	176.4 (4,480)	162.0 (4,115)
4.7		83.6 (2,125)	83.6 (2,125)	83.6 (2,125)	83.6 (2,125)	84.8 (2,155)
4.8		43.0 (1,095)	43.0 (1,095)	43.0 (1,095)	43.0 (1,095)	43.5 (1,105)
4.19		130.9 (3,325)	133.1 (3,380)	135.4 (3,440)	136.8 (3,475)	162.2 (4,120)
4.20		89.6 (2,275)	91.7 (2,330)	94.1 (2,390)	95.5 (2,425)	102.0 (2,590)
4.21		41.9 (1,065)	41.9 (1,065)	43.7 (1,110)	43.7 (1,110)	50.0 (1,270)
4.22		1.6x3.9x41.3 (40x100x1,050)	1.6x3.9x41.3 (40x100x1,050)	1.8x4.9x41.3 (45x125x1,050)	1.8x4.9x41.3 (45x125x1,050)	2.0x5.9x47.2 (50x150x1,200)
4.23		II/A	II/A	III/A	III/A	III/A
4.24		38.3 (973)	38.3 (973)	40.35 (1,025)	40.35 (1,025)	44.6 (1,132)
4.31		4.33 (110)	4.33 (110)	4.33 (110)	4.33 (110)	4.3 (110.5)
4.32		5.31 (135)	5.31 (135)	5.31 (135)	5.31 (135)	5.1 (130)
4.34.1		142.3 (3,615)	144.3 (3,665)	146.5 (3,720)	147.6 (3,750)	163.9 (4,164)
4.35		76.2 (1,935)	78 (1,980)	80.3 (2,040)	81.5 (2,070)	90.5 (2,298)
4.36	25.4 (644)	25.4 (644)	25.4 (644)	25.4 (644)	29.5 (750)	
Performance Data	5.1	10.6/10.9 (17/17.5)	10.6/10.9 (17/17.5)	10.3/10.9 (16.5/17.5)	10.3/10.9 (16.5/17.5)	10.2/10.5 (16.4/16.9)
	5.2	124/128 (0.63/0.65)	122/128 (0.62/0.65)	120/128 (0.61/0.65)	118/128 (0.60/0.65)	120.1/126.0 (0.61/0.64)
	5.3	100.4/90.5 (0.51/0.46)	100.4/90.5 (0.51/0.46)	100.4/90.5 (0.51/0.46)	100.4/90.5 (0.51/0.46)	100.4/88.6 (0.51/0.45)
	5.5	4,760/3,880 (17,540/17,250)	3,950/3,920 (17,540/17,410)	4,100/4,010 (18,230/17,850)	3,920/3,870 (17,440/17,220)	7,181/7,209 (31,987/32,115)
	5.6	4,400/4,300 (19,580/19,130)	4,410/4,350 (19,610/19,330)	4,620/4,470 (20,520/19,880)	4,420/4,300 (19,630/19,130)	7,154/8,224 (31,870/36,632)
	5.7	33.0/54.4	28.0/48.6	25.5/43.5	22.0/39.1	36.0/64.0
	5.8	37.5/62.3	30.4/53.3	28.8/49.6	24.8/44.2	42.0/77.0
	5.10	Foot/Hydraulic	Foot/Hydraulic	Foot/Hydraulic	Foot/Hydraulic	Foot/Hydraulic
Combustion Engine	7.1	GCT/K25	GCT/K25	GCT/K25	GCT/K25	PSI/4X 4.3L
	7.2	59.0 (44.0)	59.0 (44.0)	59.0 (44.0)	59.0 (44.0)	94.0 (70.0)
	7.3	2,600	2,600	2,600	2,600	2500
	7.3.1	132.9@1,600 (180.2)@1,600	132.9@1,600 (180.2)@1,600	132.9@1,600 (180.2)@1,600	132.9@1,600 (180.2)@1,600	209.4@1,800 (284)@1,800
	7.4	4/2,488	4/2,488	4/2,488	4/2,488	6/4,294
	7.10	12/50	12/50	12/50	12/50	12/75
Oth.	10.1	2,260 (156)	2,260 (156)	2,260 (156)	2,260 (156)	2,030 (140)
	10.2	15.9 (60)	15.9 (60)	15.9 (60)	15.9 (60)	31.7 (120)

Characteristics	1.1	Doosan	Doosan	Doosan	Doosan	Doosan
	1.2	GC355-9 BCS	GC455-9	GC455-9 BCS	GC55C-9	GC55C-9 BCS
	1.3	LP	LP	LP	LP	LP
	1.4	Seated	Seated	Seated	Seated	Seated
	1.5	8,000 (3,629)	10,000 (4,536)	10,000 (4,536)	12,000 (5,443)	12,000 (5,443)
	1.6	24 (610)	24 (610)	24 (610)	24 (610)	24 (610)
	1.8	17.6 (447)	18.0 (457)	17.6 (447)	18.0 (457)	18.0 (457)
	1.9	61.8 (1,570)	70.5 (1,790)	61.8 (1,570)	70.5 (1,790)	70.5 (1,790)
	Weight	2.1	12,808 (5,810)	15,754 (7,146)	14,658 (6,649)	16,702 (7,576)
2.2		18,378/2,430 8,336/1,102)	20,830/4,924 (9,448/2,234)	21,744/2,914 (9,863/1,322)	23,948/4,753 (10,863/2,156)	24,257/4,083 (11,003/1,852)
2.3		4,992/7,816 (2,264/3,545)	4,869/10,885 (2,208/4,937)	4,884/9,774 (2,215/4,433)	4,795/11,906 (2,175/5,401)	5,104/11,236 (2,315/5,097)
Tires	3.1	C	C	C	C	C
	3.2	22 x 9 x16	22 x 12 x16	22 x 12 x16	22 x 12 x16	22 x 12 x16
	3.3	18 x 7 x 12.2	18 x 8 x 12.2	18 x 8 x 12.2	18 x 8 x 12.2	18 x 8 x 12.2
	3.5	2/2	2/ 2	2/ 2	2/ 2	2/ 2
	3.6	41.0 (1,042)	43.9 (1,116)	43.9 (1,116)	43.9 (1,116)	43.9 (1,116)
	3.7	41.1 (1,044)	41.1 (1,044)	41.1 (1,044)	41.1 (1,044)	41.1 (1,044)
	Dimensions	4.1	5/6	5/6	5/6	5/6
4.2		84.1 (2,135)	86.0 (2,185)	86.0 (2,185)	86.0 (2,185)	86.0 (2,185)
4.3		6.3 (160)	6.3 (160)	6.3 (160)	6.3 (160)	6.3 (160)
4.4		113.4 (2,880)	113.4 (2,880)	113.4 (2,880)	103.5 (2,630)	103.5 (2,630)
4.5		162.0 (4,115)	169.9 (4,315)	169.9 (4,315)	160.0 (4,065)	160.0 (4,065)
4.7		84.8 (2,155)	84.8 (2,155)	84.8 (2,155)	84.8 (2,155)	84.8 (2,155)
4.8		43.5 (1,105)	43.5 (1,105)	43.5 (1,105)	43.5 (1,105)	43.5 (1,105)
4.19		162.2 (4,120)	162.2 (4,120)	162.2 (4,120)	162.2 (4,120)	162.2 (4,120)
4.20		97.6 (2,480)	105.9 (2,690)	101.3 (2,573)	108.3 (2,750)	104.5 (2,655)
4.21		50.0 (1,270)	55.9 (1,420)	55.9 (1,420)	55.9 (1,420)	55.9 (1,420)
4.22		2.0x5.9x47.2 (50x150x1,200)	2.4x5.9x47.2 (60x150x1,200)	2.4x5.9x47.2 (60x150x1,200)	2.4x5.9x47.2 (60x150x1,200)	2.4x5.9x47.2 (60x150x1,200)
4.23		III/A	IV/A	IV/A	IV/A	IV/A
4.24		44.6 (1,132)	50.8 (1,290)	50.8 (1,290)	50.8 (1,290)	50.8 (1,290)
4.31		4.3 (110.5)	4.3 (110.5)	4.3 (110.5)	4.3 (110.5)	4.3 (110.5)
4.32		5.1 (130)	5.1 (130)	5.1 (130)	5.1 (130)	5.1 (130)
4.34.1		148.3 (3,767)	160.6 (4,078)	153.7 (3,905)	162.8 (4,136)	160.4 (4,073)
4.35		82.8 (2,104)	95.1 (2,415)	87.9 (2,232)	97 (2,463)	94.5 (2,400)
4.36	29.5 (750)	29.5 (750)	29.5 (750)	29.5 (750)	29.5 (750)	
Performance Data	5.1	10.2/10.5 (16.4/16.9)	10.0/10.5 (16.1/16.9)	10.2/10.4 (16.4/16.8)	10.0/10.5 (16.0/16.9)	10.0/10.5 (16.1/16.9)
	5.3	120.1/126.0 (0.61 /0.64)	116.1/126.0 (0.59/0.64)	116.1/126.0 (0.59/0.64)	110.2/126.0 (0.56/0.64)	110.2/126.0 (0.56/0.64)
	5.5	100.4/88.6 (0.51/0.45)	100.4/88.6 (0.51/0.45)	100.4/88.6 (0.51/0.45)	100.4/ 88.6 (0.51/0.45)	100.4/88.6 (0.51/0.45)
	5.6	7,198/7,227 (32,066/32,193)	7,016/7,143 (31,252/31,821)	7,152/7,181 (31,860/31,987)	6,939/7,117 (30,909/31,703)	6,948/7,128 (30,948/31,752)
	5.6	8,270/ 8,241 (36,838/36,711)	8,070/8,153 (35,946/36,319)	8,224/8,195 (36,632/36,505)	7,993/8,127 (35,603/36,201)	8,001/8,136 (35,643/36,240)
	5.7	38.0/69.0	29.0/51.0	34.0/56.0	25.0/47.0	25.0/49.0
	5.8	44.0/84.0	33.0/61.0	35.0/68.0	29.0/56.0	29.0/58.0
	5.10	Foot/Hydraulic	Foot/Hydraulic	Foot/Hydraulic	Foot/Hydraulic	Foot/Hydraulic
Combustion Engine	7.1	PSI/4X 4.3L	PSI/4X 4.3L	PSI/4X 4.3L	PSI/4X 4.3L	PSI/4X 4.3L
	7.2	94 (70)	94 (70)	94 (70)	94 (70)	94 (70)
	7.3	2,500	2,500	2,500	2,500	2,500
	7.3.1	209.4@1,800 (284.0)@1,800	209.4@1,800 (284.0)@1,800	209.4@1,800 (284.0)@1,800	209.4@1,800 (284.0)@1,800	209.4@1,800 (284.0)@1,800
	7.4	6/4,294	6/4,294	6/4,294	6/4,294	6/4,294
	7.10	12/75	12/75	12/75	12/75	12/75
Oth.	10.1	2,030 (140)	2,030 (140)	2,030 (140)	2,030 (140)	2,030 (140)
	10.2	31.7 (120)	31.7 (120)	31.7 (120)	31.7 (120)	31.7 (120)



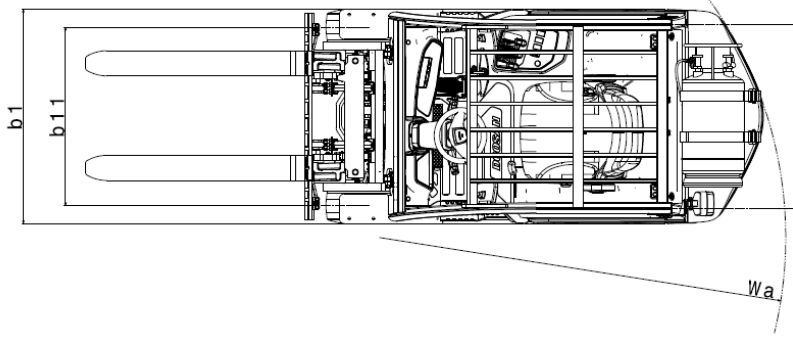
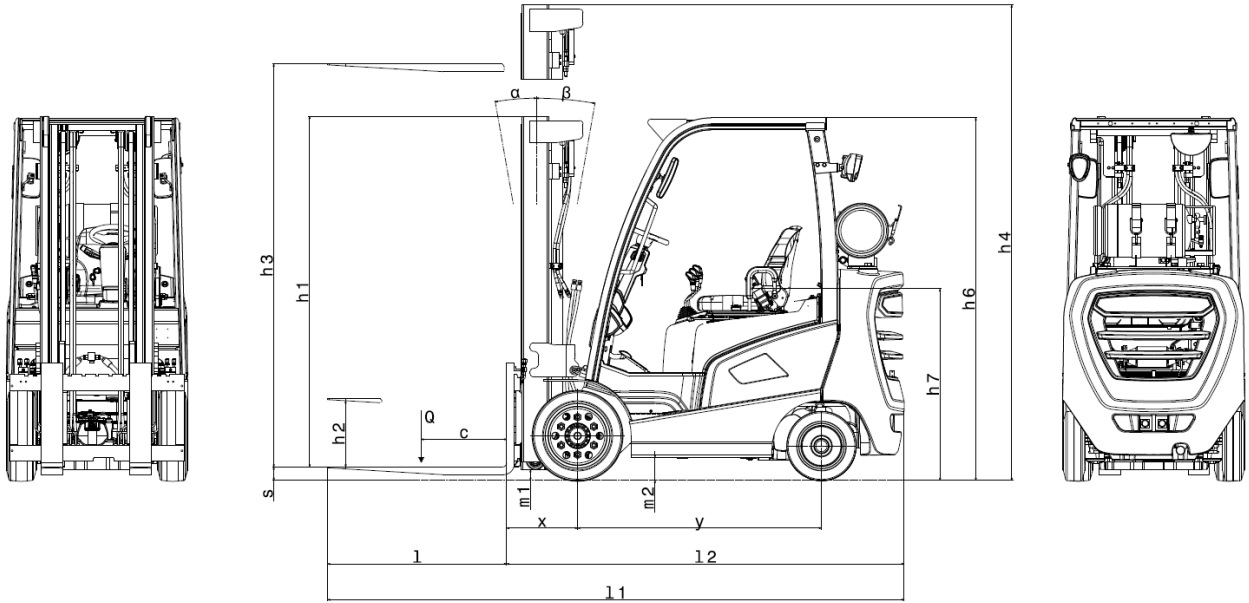

Doosan Industrial Vehicle America Corp.
 Website: www.doosanlift.com

AUTHORIZED DEALER

PSCGCS-9V1_SPEC

2019 JAN