

# SELLICK

# S150



## ROUGH TERRAIN FORKLIFT



15,000 lb. Capacity

Tier 4 Compliant Engine

Powershift Transmission

Powerful

Rugged

Dependable



## Powerful - Dependable

**S150** The S150 lift capacity is 15,000 lbs @ a 24" load center. Engineered with productivity and efficiency in mind, the S150 is ideal for heavy industrial applications and provides excellent fuel economy.

### ● **Powered by ECOMAX T4**

74 hp, direct injection, common rail, electronic, 4 cylinder diesel engine exceeds regulatory compliance for Tier 4 Final emissions standards.

- Ultra clean burn technology allows for no Selective Catalyst Reduction (SCR) exhaust aftertreatment fluid.
- No Diesel Particulate Filter (DPF) needed.
- Reduced fuel consumption.
- High torque at low speeds (209 ft lbs @ 1,200 rpm).

### ● **Operator Safety & Comfort**

- ROPS / FOPS certified overhead guard.
- Cab is ISO mounted to reduce noise and vibration.
- Ergonomic, automotive inspired controls for safe & efficient operation.

### ● **Multi-function Digital LCD Screen**

- Fuel Level.
- Engine Coolant Temperature.
- System Voltage.
- RPM and Hour Meter Reading.
- On board diagnostics reduces downtime.

Backlighting provides better visibility in dark conditions. Instrument panel swings forward for easy access to fuse panel.

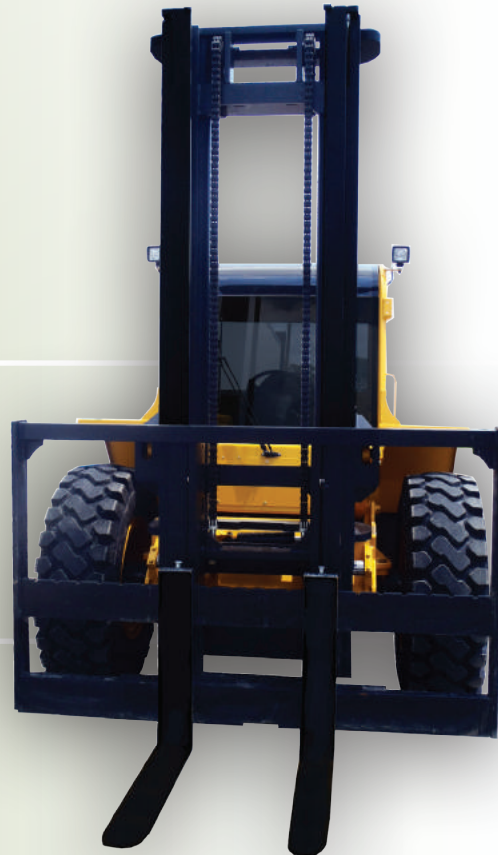

S150 ROUGH TERRAIN FORKLIFT

## Agile - Versatile

**S150** Designed to meet the demands of high hour applications.

### ● Mast / Carriage

- Sellick SEE-THRU® all roller, sideshifting mast design gives you line-of-sight view of the forks and load.
- Integral hydraulic fork positioning carriages available. (No downrating of lift capacity.)



### ● Transmission

Equipped with a fully automatic, four speed, Powershift Transmission.

- Power reversing.
- 2WD and 4WD options available.
- On the go 4WD engagement.



### ● Axles

- Heavy duty rigid front axle with 12 bolt pattern.
- Torque proportioning differential.
- Enclosed oil cooled, wet disc brakes for long life.
- Rear steer axle features sealed tapered roller bearings.



# S150 ROUGH TERRAIN FORKLIFT

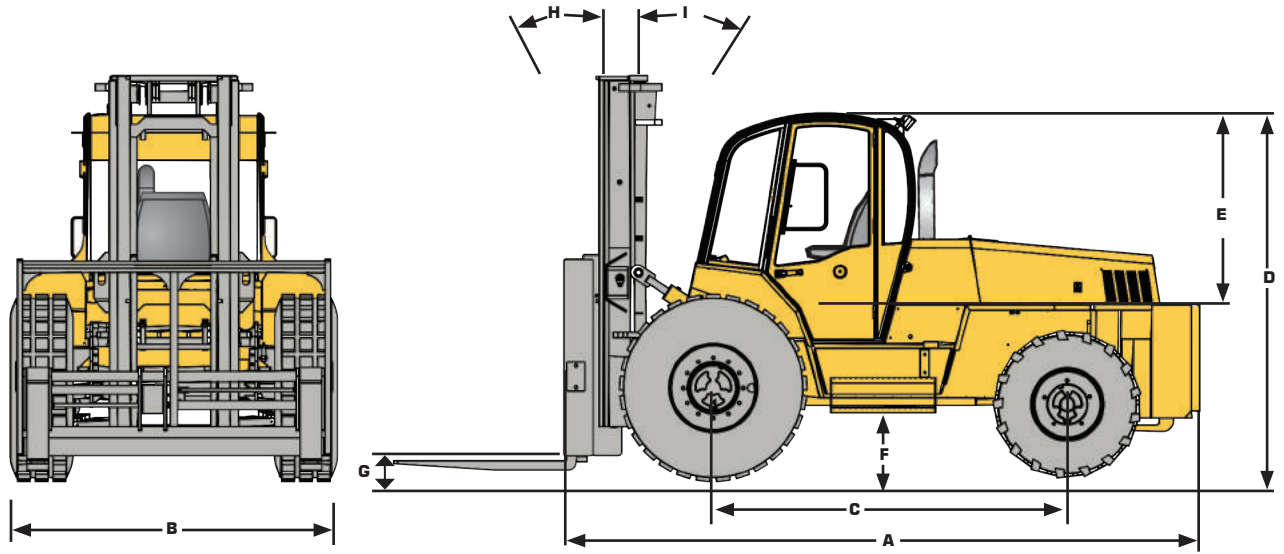

MODEL	REF	S150
Overall length	A	173" / 4395 mm
Overall width	B	90" / 2299 mm
Wheelbase	C	99" / 2514 mm
Height to top of overhead guard	D	99" / 2514 mm
Distance from seat to overhead guard	E	43" / 1092 mm
Frame underclearance	F	18" / 457 mm
Mast underclearance	G	12" / 305 mm
Mast tilt - forward	H	15°
Mast tilt - rearward	I	12°
Lift capacities @ 24" load center		15000 lbs / 6304 kg
Base operating weight (standard chassis & mast)		24100 lbs / 10931 kg
Outside turning radius		189" / 4801 mm
Gradeability		25%
Max. travel speed		15 mph / 25 kph
Tire size and type		Drive : 15.5 X 25, 16 ply Steer: 15 X 19.5, 14 ply
Electrical system		Alternator - 95 A; Battery 1 000 CCA (12 volt system)
Engine model		ECOMAX T4
Cylinders		4
Engine output (gross power)		74 hp @ 2200 rpm
Peak torque		295 ft lbs @ 1200 rpm
Transmission manufacturer & type		PS750 Powershift
Axles		Front: PD87 Series Rear: S55 Series

Because of our constant dedication to product improvement, all specifications are subject to change without notice.

— All Sellick forklifts meet or exceed all ANSI B56.6 safety standards. —

**SELICK**  
**Sellick Equipment Limited**  
 P.O. Box 1000/358 Erie Street North  
 Harrow, Ontario, Canada N0R 1G0  
 519-738-2255 • sellick@mnsi.net  
 Visit us at www.sellickequipment.com



Sold & serviced by: